

BRD140 and BRD140 (01) barriers assembly and installation manual

Read this manual carefully before performance of work

BRD140 is delivered partially assembled and is assembled by the customer from the following elements: finite posts (1 pc. 1000 mm high and 1 pc. 600 mm high) with blind mounting holes, black pipes (2 pcs) - section elements, fixing pipes (1 pc. long and 1 pc. short), screws, post caps, self-tapping anchors (Fig. 1).

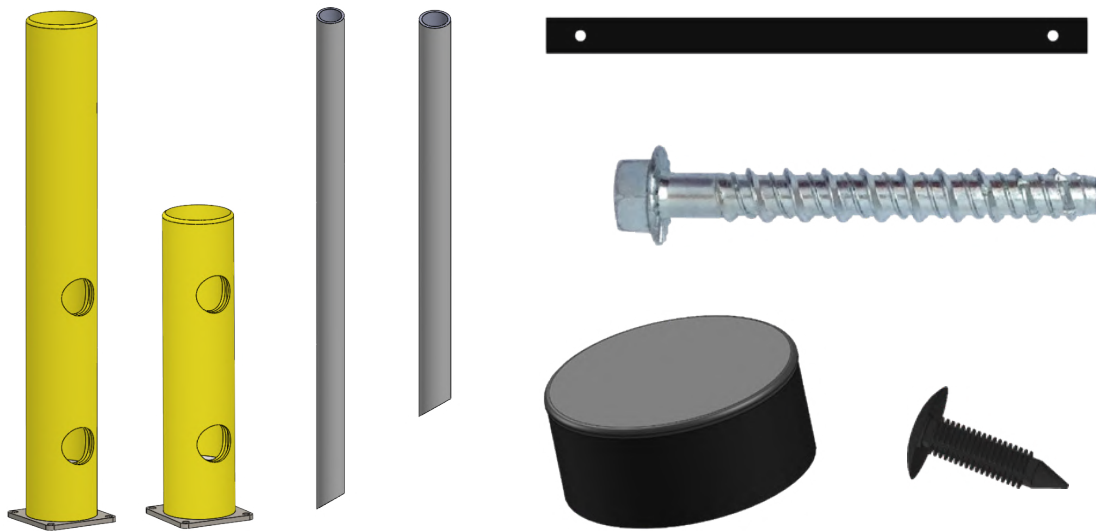

Figure 1. The BRD140 barrier components (list from left to right): finite post (1 pc. larger and 1 pc. smaller) with blind mounting holes, fixing pipes, section elements (2 pcs), self-tapping anchor, post caps, screws.

In addition to the listed items, the BRD140(01) kit, includes a 600 mm high connecting post with through-mounting holes, 2 additional short 20 mm diameter fixing pipes, 4 black pipes instead of two - section elements. If necessary, BRD140 and BRD140(01) are completed with a BV140/1000 barrier.

The algorithm for assembling BRD140 barrier elements is as follows:

1. Insert the two black section elements against the stop into the holes of the larger finite post. The axes of the through-mounting holes in the section elements both here and later on must be placed vertically. At the same time, the end of the section element must stop at the inner wall of the pipe inside the post, while the contour of the section element mounting hole must be positioned at a tangent to the inner surface of the inner pipe of the post. (Fig. 2, key lines are marked in blue).
2. Use the longer of the available fixing pipes through the hole to fix both elements of the section inside the finite post (Fig. 2).

BRD140 and BRD140 (01) barriers assembly and installation manual

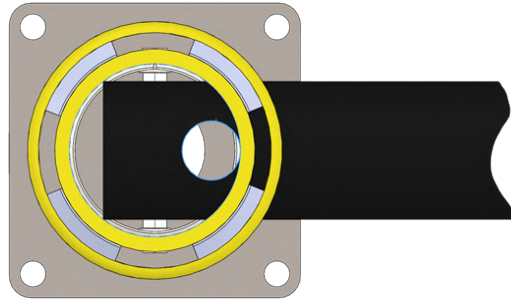

Figure 2. Proper placement of the end of the section element inside the post.

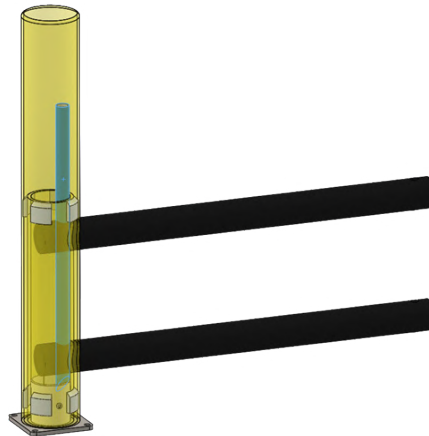

Figure 3. Section fixing in the post.

3. Hammer the fixing pipe to fix the section in the post (Fig. 3).
4. Install a smaller finite post on the opposite side of the section, in a similar way, as described in paragraphs 1-3 of the algorithm.
5. Cover the tops of the posts with caps. To fix the caps, drill 7 mm holes at a distance of 20 mm from the top of the post in one plane and insert the screws. (Fig. 4)

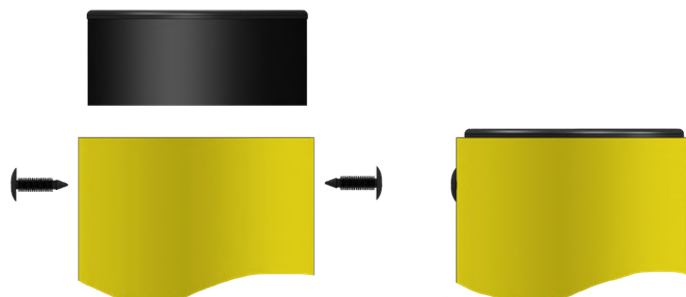

Figure 4. Installation of post caps

BRD140 and BRD140 (01) barriers assembly and installation manual

The algorithm for assembling BRD140 (01) barrier elements is as follows:

1. Perform the actions specified in paragraphs 1-4 of the BRD140 barrier assembly algorithm.
2. Insert the section elements into the intermediate post with the sides with 20 mm diameter holes, as shown in fig. 5.

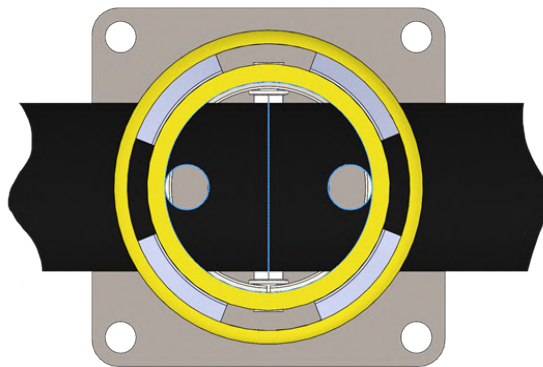

Figure 5. Arrangement of section elements in the intermediate post.

3. Hammer the 20 mm diameter fixing pipes to fix the section in the post (Fig. 6).
4. Perform the actions specified in paragraph 5 of the BRD140 barrier assembly algorithm. A sectional view of the assembled BRD140(01) barrier is shown in Figure 7.

After assembly, the BRD140 or BRD140(01) barrier must be fixed to the foundation with self-tapping anchors, which are supplied as component parts. To mark the holes, it is recommended to use the holes in the metal supports of the barrier as templates.

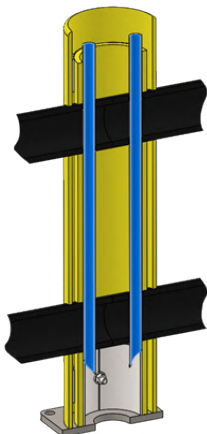

Figure 6. Sections fixing in the intermediate post. Fixing pipes are marked in blue in the figure.

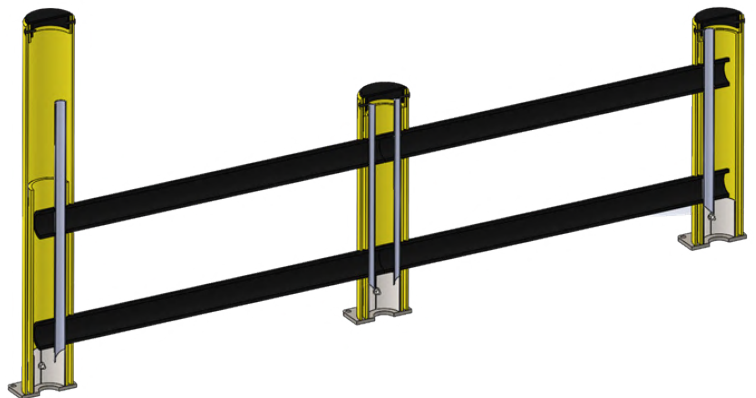

Figure 7. Section of the assembled BRD140(01) barrier

BRD140 and BRD140 (01) barriers assembly and installation manual

In the process of installing the BV140/1000, BRD140 and BRD140(01) barriers, the recommended distance from the objects to be protected must be observed (Figure 8).

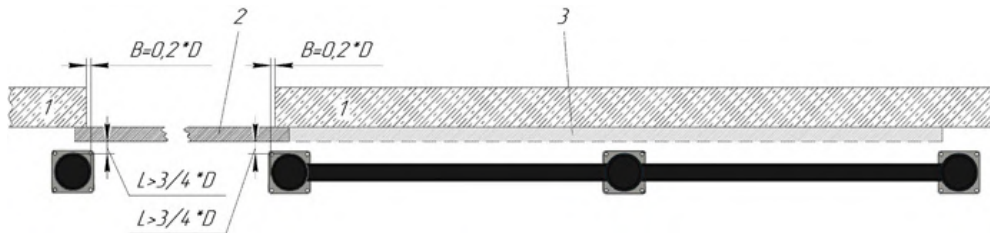

Figure 8. Distances that are recommended to be observed during the barrier installation.

Symbols in Figure 8: 1 – wall, 2 – sliding door in the closed position, 3 – sliding door in the open position.

For optimal protection of the doorway, the barrier post should overlap the doorway clearance by an amount (approximately 0.2 of the diameter D of the barrier).

The distance L between the barrier posts and the sliding door must be at least $3/4$ of the diameter D of the barrier post.

Before foundation drilling, it is recommended to move the metal support away. Make holes in the concrete surface with a 10 mm drill to a depth of at least 100 mm (Fig. 9.1). If larger diameter drill bits are used, the self-tapping anchor will lose its efficiency during the barrier service.

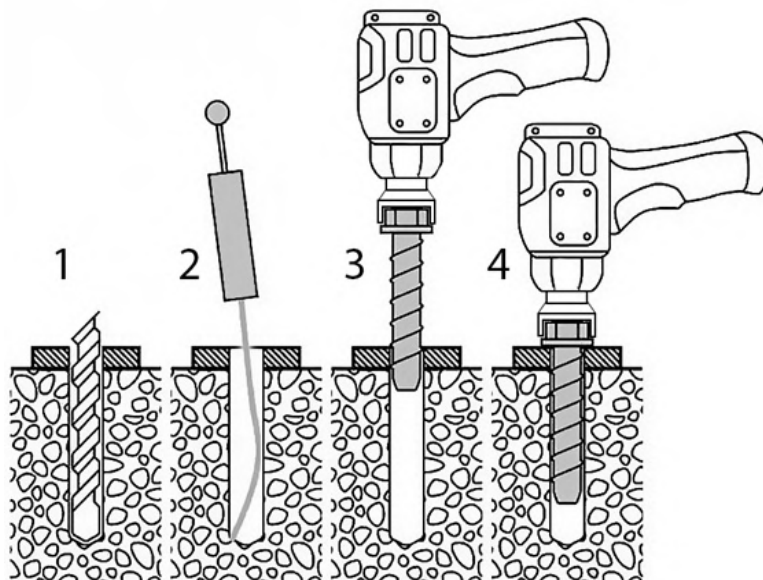

Figure 9. Barrier fixing



BRD140 and BRD140 (01) barriers assembly and installation manual

Remove the drilling products from the drilled holes (Fig. 9.2).

Install the barrier support on the prepared place and tighten the self-tapping anchors (Fig. 9.3 and 9.4).

The properly installed self-tapping anchor will screw in tightly, so it is recommended to use an impact wrench with a flexible shaft.

The impact wrench for screwing the self-tapping anchors which are supplied as component parts must provide a torque of 950 Nm and higher