

BH barriers assembly and installation manual

Read this manual carefully before performance of work

The BH barrier is delivered partially assembled and is assembled by the customer of the following elements: finite- elements, joining elements (Fig. 1), sections (Fig. 2), self-tapping anchors (Fig. 3).



Figure 1. Finite and joining elements



Figure 2. Section



Figure 3. Self-tapping anchor

When assembling the BH barrier, it is necessary to connect the finite and joining elements with the help of sections, as shown in Fig. 4:



Figure 4. Finite and joining elements connected by the section

BH barriers

assembly and installation manual

To facilitate the barrier assembly process, we recommend lubricating the black belts on the parts of the male joining and finite-elements with a soapy solution.

The assembled barrier must be fixed to the foundation using self-tapping anchors, which are supplied as component parts. To mark the holes, it is recommended to use the holes in the metal supports of the barrier as templates. After marking, before drilling the floor, we recommend putting the supports aside. Drilling should be performed with a 10 mm drill bit to a depth of at least 100 mm (Fig. 5.1). If larger diameter drill bits are used, the anchor will lose its efficiency during the barrier service. Drilling products must be removed from the holes in the foundation (Fig. 5.2). Install the barrier posts in loco and tighten the anchors. The correctly installed self-tapping anchor will screw in tightly, so it is recommended to use an impact wrench with a flexible shaft (Fig. 5.3 and 5.4).

The impact wrench for screwing the self-tapping anchors which are supplied as component parts must provide a torque of 950 Nm and higher.

If a BH barrier with such a large number of sections is used to protect the area that it is difficult to install it after the complete assembly of the product, it is necessary to fix the supports on the foundation at intermediate stages of assembly. In any case, it should be taken into account that the long length of the multi-section barrier will lead to the errors accumulation in the geometrical arrangement of the section elements, due to which the actual length of protection may deviate from the value specified in the project. Therefore, to ensure the possibility of the best positioning of the barrier in relation to the objects to be protected, it is necessary to install the product after its assembly when applicable.

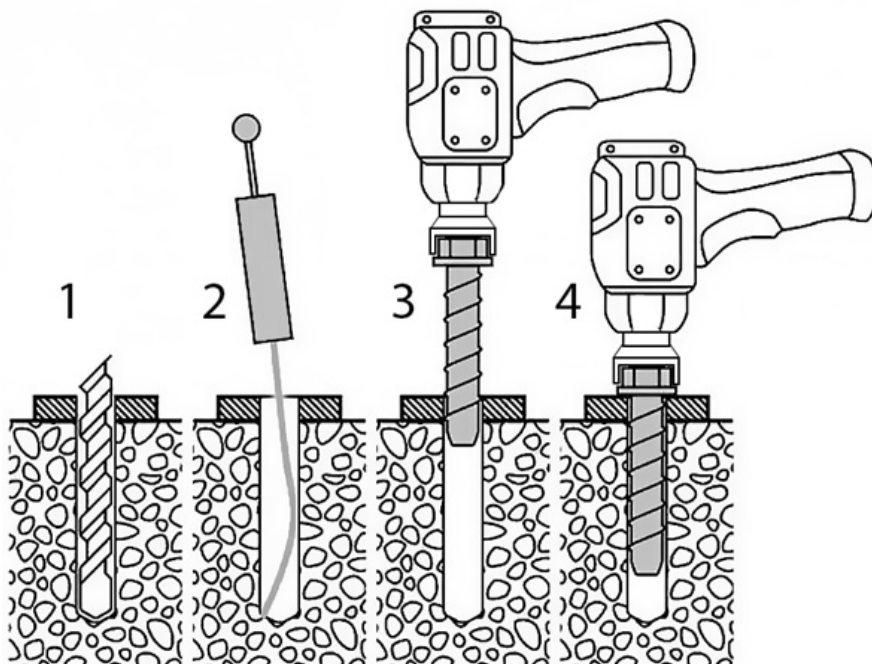

Figure 5. Barrier fixing



BH barriers **assembly and installation manual**

To ensure the top efficiency of flexible protection with BH barriers, they must be installed with the interval between the sections and the protected objects not less than 80-120mm.

The single-section BH barrier is assembled in the same manner. For this, two finite-elements and one section are used.